

### Technical Specifications

Dimensions	MPD.1818
<b>A</b> — Working Height	18,00 m
<b>B</b> — Platform Height— lifted	16,00 m
<b>D</b> —Platform Height— Lowered	2,00 m
<b>D+C</b> — Height—Stowed folding guardrails	3,10 m
Height—Stowed rails folded	2,60 m
<b>C</b> —Guardrail Height	1,10 m
<b>ExF</b> — Platform Dimensions	4,20 x 1,80 m
<b>K</b> — Extension Deck	1,50 m
<b>G</b> — Platform Width	1,80 m
<b>L</b> — Total Length	4,60 m
<b>J</b> — Wheelbase	2,75 m
Ground Clearance — Center	20 cm
Productivity	
Lift Capacity	400 kg
Extension Deck Capacity	120 kg
Maximum Platform Occupancy	3
Raise / Lower Speed	130 / 140 sn
Weight	8500 kg
Grade ability	%20
Drive Speed (Raised / Stowed)	0,8 / 2,4 km
Tyres—Solid non-marking	650×100 mm
Turning Radius	6000 mm
Power	
Power Source	48 V Battery
Lifting System / Drive Type	48 V Battery
Battery	48V 600Ah
Charger	48V 80 Ah

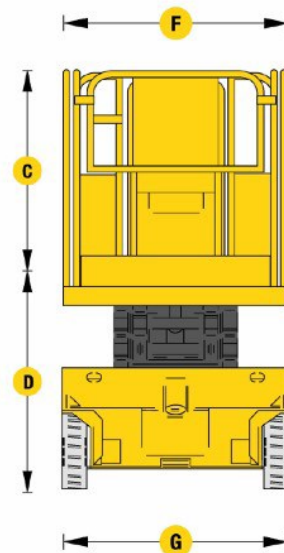
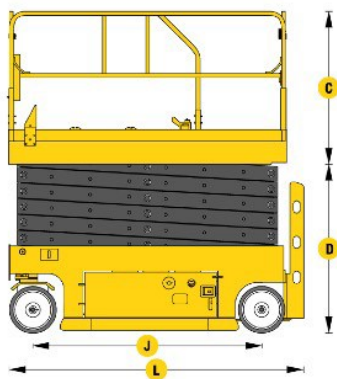
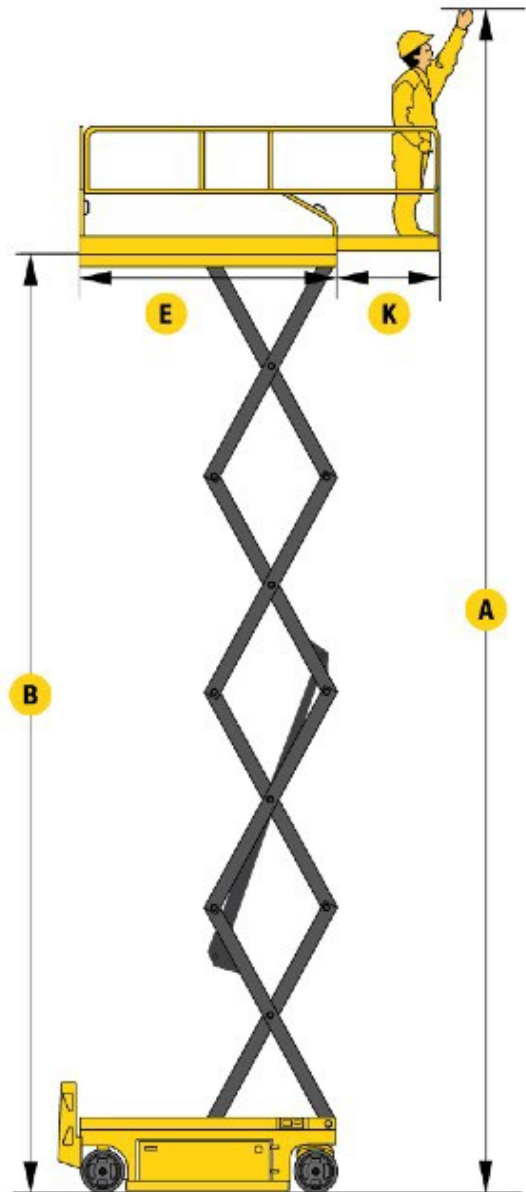

Measurements	Platform	Lifting Type	Optional
<ul style="list-style-type: none"> <li>18,0 m working height</li> <li>400 kg lifting capacity</li> </ul>	<ul style="list-style-type: none"> <li>4,20x1,80 m platform</li> <li>1,50 m deck extension</li> </ul>	<ul style="list-style-type: none"> <li>48V Battery</li> </ul>	<ul style="list-style-type: none"> <li>Airline to platform</li> <li>AC Power on the platform</li> <li>Platform work lights</li> <li>Special customer paint</li> <li>Hydraulic Outriggers</li> </ul>

### Platform

- Roll-out deck extension
- Drivable at full height
- Fold down handrails
- Self lock gate on platform
- Removable platform console box
- Lanyard attach points
- Full proportional drive joystick control
- Proportional lift/lower speed control
- Overload sensor

### Power and Transmission

- 48V 600 Ah tractional batteries
- Swing-out battery/electrical compartment doors
- 80 Amp automatic battery charger
- Charger protection
- Dual motor direct hydraulic front wheel drive & steer
- 2WD
- Dual rear wheel automatic hydraulic brakes
- Emergency brake release

### Functional Equipment & Accessories

- Emergency lowering system
- On-board diagnostic system
- Battery condition indicator
- Hour meter
- Lubrication free scissor arm bushing
- Scissor maintenance bar
- Cylinder holding valve
- Manual descent
- Horn
- Non-marking solid tyres
- Slope motion cut out
- All motion alarm
- Descent alarm
- Tie down lugs
- Forklift pockets
- Tilt level sensor with audible alarm



### ONDLIFT Mak. San. Tic. Ltd. Şti

**Factory:** Organize Sanayi Bolgesi 2004 Cad. No: 4  
Turgutlu/Manisa/TURKEY

**Showroom:** İmes San. Sit. C.302 Sk. No:13  
Y.Dudullu/Umraniye/Istanbul/TURKEY

Tel: 0090 236 332 5050

ondlift@ondlift.com

Product specifications are subject to change without any notice or obligation. The photographs and/or drawing in this documents are for illustrative purpose only. All productions of OndLift, manufacturing for CE standards.

**Turkey**  
Discover the potential

Onder Lift Celik



**43rd Years Anniversary**

Your warehous partner

Onder Grup Company