

Technical Specifications

Dimensions	MPD.1412
A — Working Height	14,00 m
B — Platform Height— lifted	12,00 m
D —Platform Height— Lowered	1,65 m
D+C — Height—Stowed folding guardrails	2,75 m
Height—Stowed rails folded	2,10 m
C —Guardrail Height	1,10 m
ExF — Platform Dimensions	2,30 x 1,15 m
K — Extension Deck	1,00 m
G — Platform Width	1,15 m
L — Total Length	2,50 m
J — Wheelbase	1,90 m
Ground Clearance — Center	10 cm
Ground Clearance with pothole guards deployed	1,90 cm
Productivity	
Lift Capacity	300 kg
Extension Deck Capacity	100 kg
Maximum Platform Occupancy	2
Raise / Lower Speed	70 / 80 sn
Weight	2900 kg
Grade ability	%20
Drive Speed (Raised / Stowed)	0,8 / 2,4 km
Tyres—Solid non-marking	381×127 mm
Turning Radius	2500 mm
Power	
Power Source	24 V Battery
Lifting System / Drive Type	24 V Battery
Battery	4x6V 242 Ah
Charger	24V 30 Ah

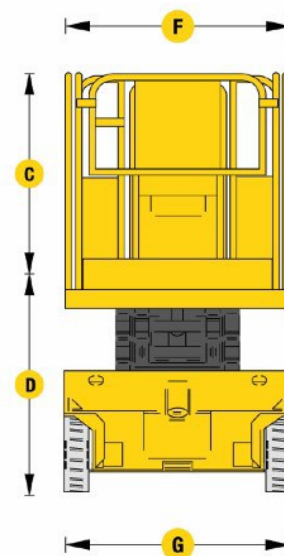
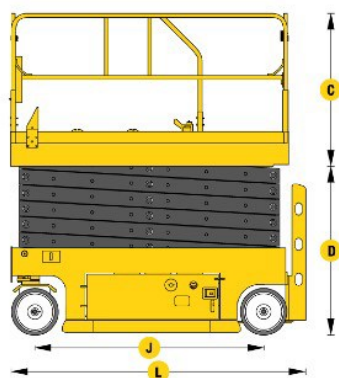
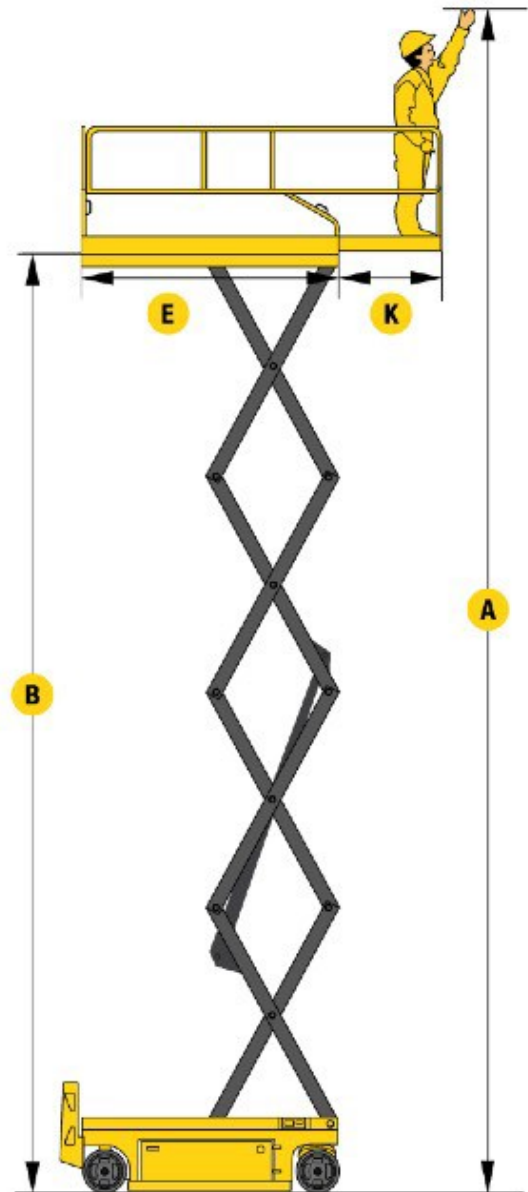

Measurements	Platform	Lifting Type	Optional
<ul style="list-style-type: none"> 14,0 m working height 300 kg lifting capacity 	<ul style="list-style-type: none"> 2,30x1,15 m platform 1,0 m deck extension 	<ul style="list-style-type: none"> 24V Battery <p>Drive Type</p> <ul style="list-style-type: none"> 24V Battery 	<ul style="list-style-type: none"> Airline to platform AC Power on the platform Platform work lights Special customer paint

Platform

- Roll-out deck extension
- Drivable at full height
- Fold down handrails
- Self lock gate on platform
- Removable platform console box
- Lanyard attach points
- Full proportional drive joystick control
- Proportional lift/lower speed control
- Overload sensor

Power and Transmission

- 4x6V 242 Ah deep cycle batteries
- Swing-out battery/electrical compartment doors
- 30 Amp automatic battery charger
- Charger protection with data charging data details
- Dual motor direct hydraulic front wheel drive & steer
- 2WD
- Dual rear wheel automatic hydraulic brakes
- Emergency brake release

Functional Equipment & Accessories

- Automatic pothole protection system
- Emergency lowering system
- On-board diagnostic system
- Battery condition indicator
- Hour meter
- Lubrication free scissor arm bushing
- Scissor maintenance bar
- Cylinder holding valve
- Manual descent
- Horn
- Non-marking solid tyres
- Slope motion cut out
- All motion alarm
- Descent alarm
- Tie down lugs
- Forklift pockets
- Tilt level sensor with audible alarm



ONDLIFT Mak. San. Tic. Ltd. Şti

Factory: Organize Sanayi Bolgesi 2004 Cad. No: 4
Turgutlu/Manisa/TURKEY

Showroom: İmes San. Sit. C.302 Sk. No:13
Y.Dudullu/Umraniye/Istanbul/TURKEY

Tel: 0090 236 332 5050

ondlift@ondlift.com

Product specifications are subject to change without any notice or obligation. The photographs and/or drawing in this documents are for illustrative purpose only. All productions of OndLift, manufacturing for CE standards.

Turkey
Discover the potential

Onder Lift Celik



43rd Years Anniversary

Your warehouse partner

Onder Grup Company